

Square

PTZ Series



Appearance

Sensing type	Disffuse refection	Thru-beam	Retro-reflection
Sensing distance	100cm	2000cm	400cm
Beam size	φ 75mm / 1000mm	φ 800mm / 20m	φ 200mm / 4m
Output type	NPN/PNP Open-collector, ≤100mA		
Switch type	Selectable L.on/D.on		
Indicator	Motion indicator:Green;Output indicator:Yellow		
Response time	0.5ms		
Sensivity adjustment	Single turn potentiometer		
Light source	Red LED 660nm		
Operating voltage	10~30V DC ± 10%		
No-load supply current	≤25mA	Emitter≤20mA,Receiver≤15mA	≤20mA
Ambient luminance	Sunlight≤1000Lux,Incandescent lamp≤3000Lux		
Ambient temperature	-25°C~55°C no freezing		
Ambient humidity	35~85%RH, No coagulating		
Shock resistance	100G (1000m/s ²)		
Degree of protection	IP67		
Connection method	2M/3 core cable		
Material	ABS contain optic fiber(body);PMMA(lens)		
Accessories	None		Reflector
Model No.	NPN	PTZ-D70N HOT	PTZ-TM20N
	PNP	PTZ-D70P	PTZ-TM20P
			PTZ-R400N
			PTZ-R400P

Dimensions

Unit: mm

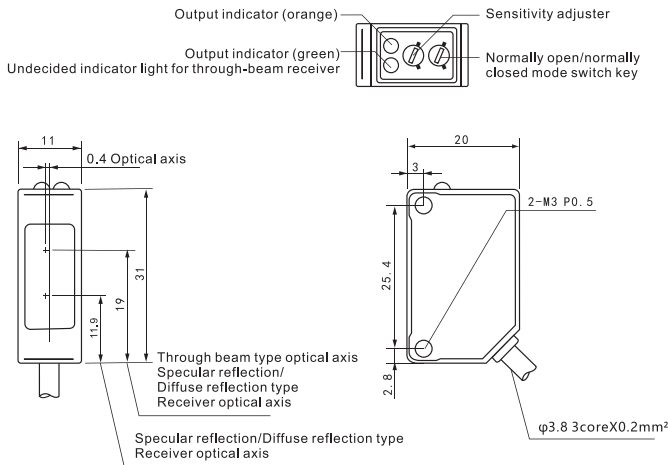

PTZ-R400 Reflector

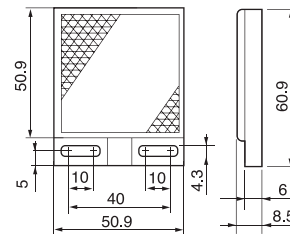

(Standard TD-11)

Circuit diagram

NPN Output

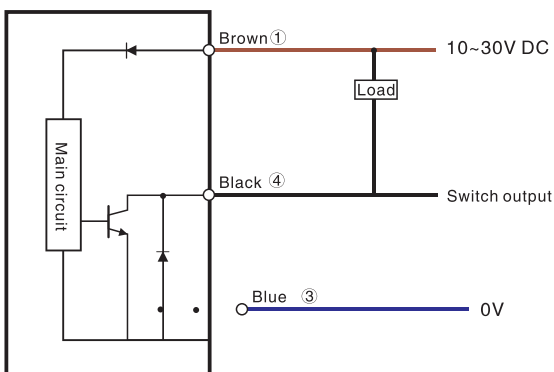

PNP Output

