

Square

PTE Series



Economical Type
NEW!

Appearance				
Sensing type	Thru-beam Reflection			
Sensing distance	10m (fixed)		10m	
Sensing object	$\phi > 12\text{mm}$, opaque			
Output type	NPN / PNP open collector			
Switch Type	L.on /D.on selectable		L.on /D.on Switchable	
Indicator	Status indicator: green, output indicator: red		Emitter: Power: green; Receiver: Operation: green, Motion: red	
Response time	150HZ			
Sensitivity	Not adjustable		Single turn potentiometer	
Light source	IR LED 623nm (modulated)			
Operating voltage	10~30V DC			
Current consumption	Emitter $\leq 16\text{mA}$; Receiver $\leq 15\text{mA}$			
Ambient light	Sunlight $\leq 10,000\text{ Lux}$, Incandescent lamp $\leq 3,000\text{ Lux}$			
Ambient temperature	$-25^{\circ}\text{C} \sim +55^{\circ}\text{C}$, No freezing			
Ambient humidity	35%~85%RH, No condensation			
Anti-vibration	10 to 50 Hz with 0.5mm amplitude for 2 hours each in X, Y, and Z directions			
Protection circuits	Power reverse polarity protection, short circuit protection			
Degree of protection	IP65			
Connection	2M / 3 cores cable 4mm diameter			
Material	Fiberglass (shell), PMMA(Window)			
Accessories	Screwdriver			
Model No.	NPN	PTE-TM10NO	PTE-TM10NC	PTE-TM10AN
	PNP	PTE-TM10PO	PTE-TM10PC	PTE-TM10AP

Dimensions

Unit: mm

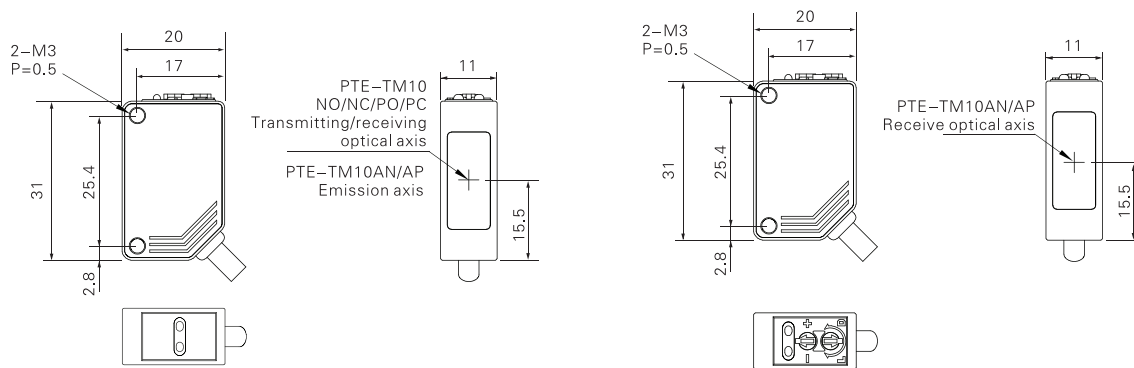

Circuit diagram

NPN Output

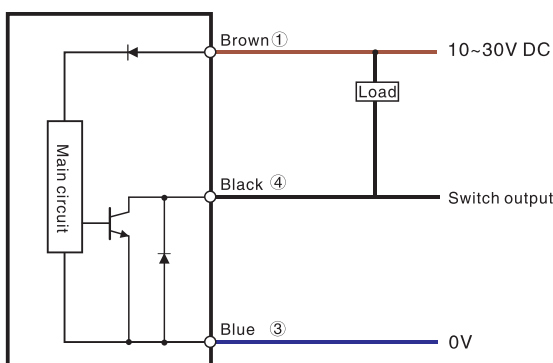

PNP Output

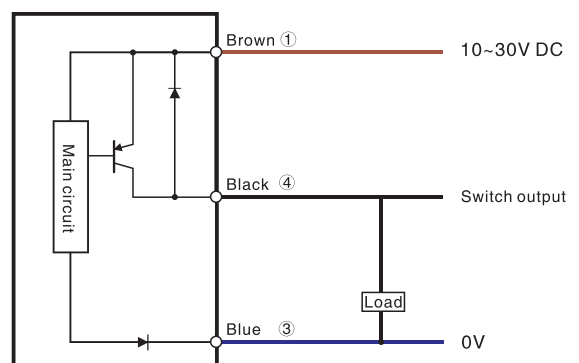



Economical Type

NEW!

Appearance							
Sensing type	Diffuse reflection		Convergent reflective	Retro-reflection			
Sensing distance	30cm	100cm	14cm	20cm	200cm	300cm	
Spot size	≈ φ 16mm / 300mm	≈ φ 50mm / 1000mm	≈ φ 9mm / 140mm	φ 10mm / 20cm	φ 50mm / 2m	φ 90mm / 3m	
Output type	NPN or PNP open collector, ≤100mA (30V DC)						
Switch type	L.on / D.on Switchable						
Indicator	Motion indicator: Red ; Operating indicator: Green						
Response time	<1ms			1ms	<1ms		
Sensitivity adjustment	Single-turn potentiometer						
Light source	Red light LED 623 nm (modulated)						
Operating voltage	10~30V DC						
Current consumption	≤20mA						
Ambient brightness	Sunlight ≤ 10000 Lux; Incandescent Lamp ≤ 3000 Lux						
Ambient temperature	-25°C~+55°C, No freezing						
Ambient humidity	35%~85%RH, No condensation						
Anti-vibration	10 ~ 50Hz, 0.5mm amplitude, 2 hours each in X, Y, Z directions						
Protective circuit	Power reverse polarity protection, output reverse polarity protection, surge protection, short circuit protection						
Degree of protection	IP65						
Connection method	2M/3 cores cable, φ 4mm						
Material	PBT+Fiberglass (Housing) , PMMA (Lens)						
Accessories	Screwdriver		Screwdriver, reflective sticker	Screwdriver, reflector			
Model No.	NPN	PTE-D30N	PTE-D70N	PTE-X09N	PTE-R20N	PTE-R200N	PTE-R300N
	PNP	PTE-D30P	PTE-D70P	PTE-X09P	PTE-R20P	PTE-R200P	PTE-R300P

Dimensions

Unit: mm

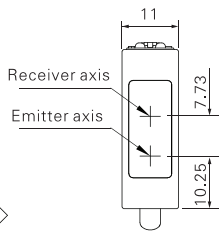
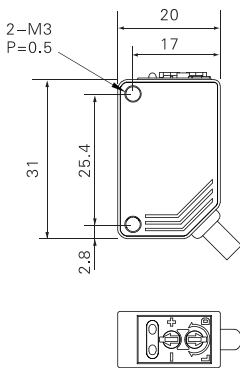

Reflector for PTE-R200

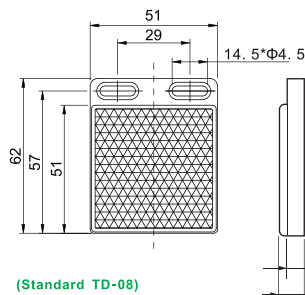

Reflector for PTE-R300

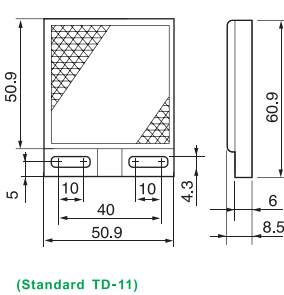

PTE-R20 Reflective Stickers

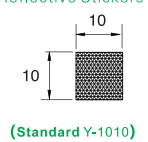

Circuit diagram

NPN Output

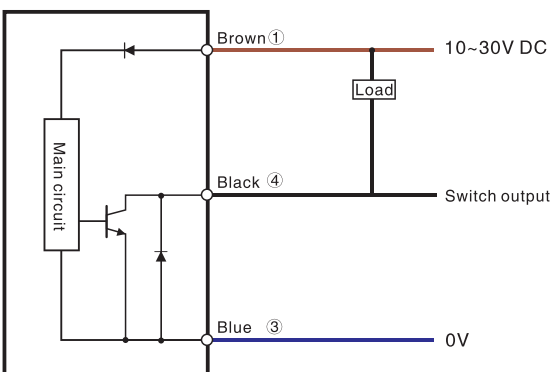

PNP Output

